

ABOUT MORGAN ADVANCED MATERIALS



Morgan Advanced Materials is a global engineering company offering world-leading competencies in materials science, specialist manufacturing and applications engineering. We focus our resources on the delivery of products that help our customers to solve technically challenging problems, enabling them to address global trends such as energy demand, advances in healthcare and environmental sustainability.

What differentiates us?

- Advanced material science and processing capabilities.
- Extensive applications engineering experience
- A strong history of innovation and reinvention.
- Consistent and reliable performance.
- A truly global footprint.
- We find and invest in the best people.

Contact email

EV@morganplc.com

Advanced Solutions for Applications in Electrified Vehicles

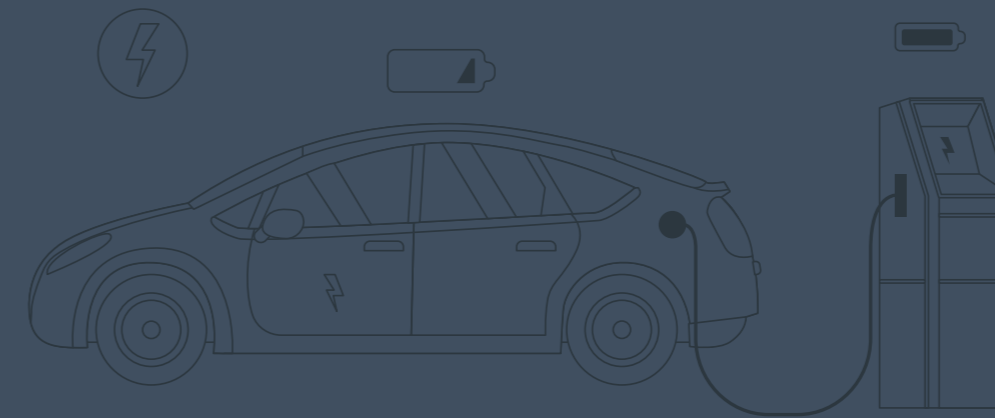

PERFORMANCE CARBON



Driving development and innovation in the global Electrified Vehicle market

Table of Contents

Company Introduction	02
Product Map in EV	03
Product Introduction	05 - 18

Morgan Advanced Materials

Morgan Advanced Materials is a global materials engineering company which designs and manufactures a wide range of high specification products with extraordinary properties, across multiple industries and geographies.

From an extensive range of advanced materials, we produce components, assemblies and systems that deliver significantly enhanced performance for our customers' products and processes. Our engineered solutions are produced to very tight tolerances and many are designed for use in extreme environments.

The company thrives on breakthrough innovation. Our materials scientists and applications engineers work in close collaboration with our customers to create outstanding, highly differentiated products that perform more efficiently, more reliably and for longer.

KEY BENEFITS:

- Proven technologies in demanding **electrified vehicle** applications
- Advanced materials innovation.
Helping our customers solve engineering challenges through market leading materials.
- Broad array of products, that enable us to deliver optimised solutions.
- Expert application engineering support
- Global footprint, providing you with support locally, when you need it

Morgan in the EV industry

Morgan provides the global automotive sector with a wide range of components used in vehicle manufacturing. Harnessing our design expertise and specialist manufacturing capabilities, we work in partnership with some of the world's largest tier-one automotive suppliers, developing competitive tailored solutions to meet the increasingly challenging demands of the sector. We are helping manufacturers improve vehicle safety, performance, energy efficiency and comfort to create more fuel efficient, safer vehicles.

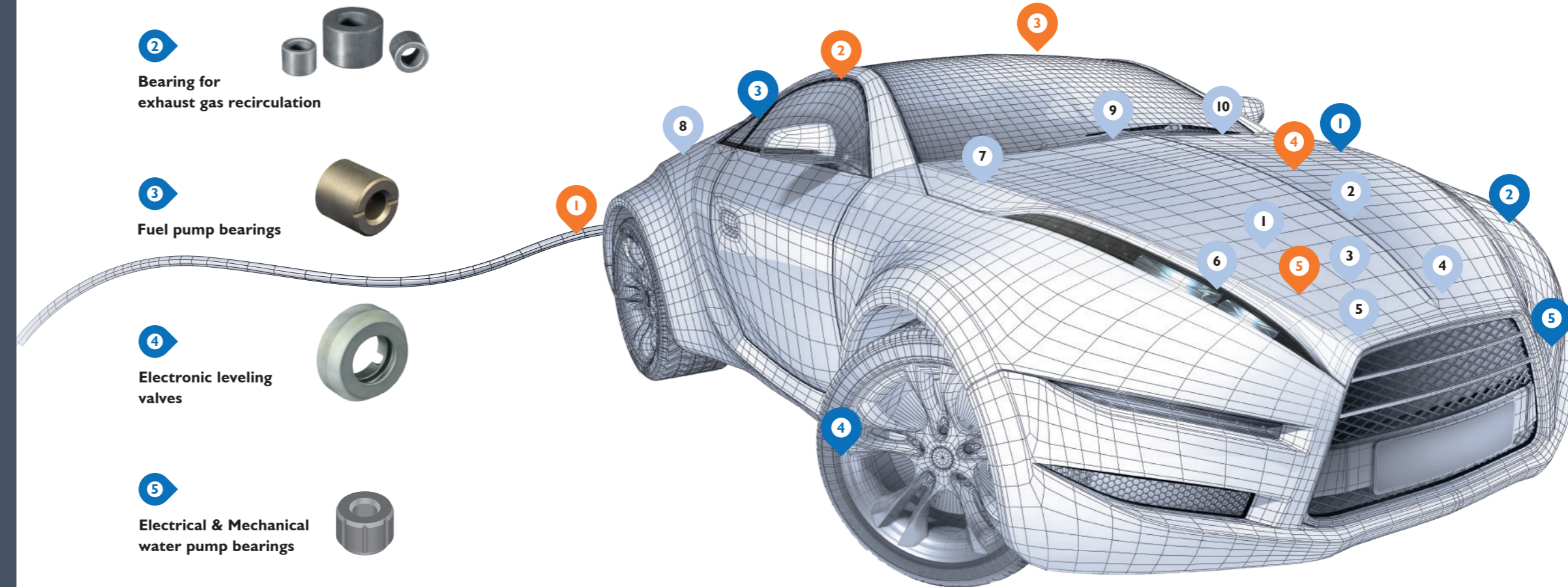
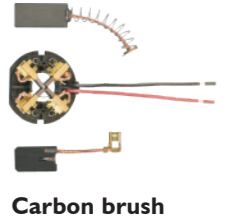
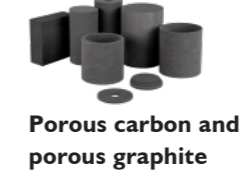
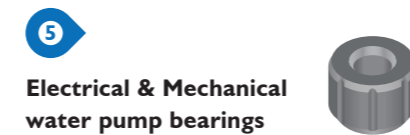
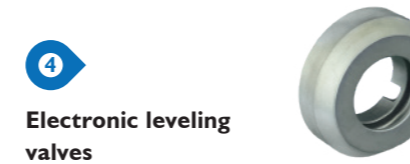
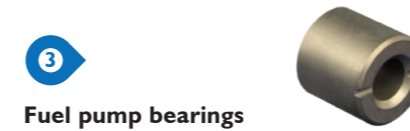

- 1 Alternator brush
- 2 Starter motor brush
- 3 HCF brush
- 4 Radiator cooling pump brush
- 5 EVP motor brush
- 6 DC motor brush
- 7 ABS motor brush
- 8 Fuel / oil pump brush
- 9 Wiper motor brush
- 10 HVAC motor brush

We design and manufacture custom components to meet specific requirements. Our carbon components are up to 60% lighter than steel, contributing to increased energy efficiency.



Vacuum Pumps for Brake Booster

We provide a selection of high performance vanes and rotors, manufactured from our special formulations of carbon graphite materials, which feature superior tribological and wear characteristics. Chemically inert and dimensionally stable they are ideally suited to automotive applications such as Vacuum Pumps for brake boosters.

Technology

Rotors

- Press to size technology enables cost effective products
- Good mechanical strength

Vanes

- Excellent wear resistance
- Superior self-lubricating properties

Our Global Advantages

- Engineered with the automotive industry leaders to ensure demanding challenges achieved
- Global manufacturing enables consistent supply of Morgan's material grades across different continents
- Global engineering and program management organisation with focus in automotive

State of the Art Development

Our Centres of Excellence are in direct contact with our production sites, supporting local and global customers with research of best suitable materials for specific applications. Morgan has implemented new test capabilities that enable endurance tests to perform endurance tests according to recognised automotive standards.



Bearing for Exhaust Gas Recirculation

Our radial bearings are able to lubricate at high engine temperatures, providing an excellent solution for regulating exhaust gas recirculation and resulting in more efficient engine systems. Our innovative materials also reduce nitrogen oxides by lowering combustion temperatures in the combustion chamber.

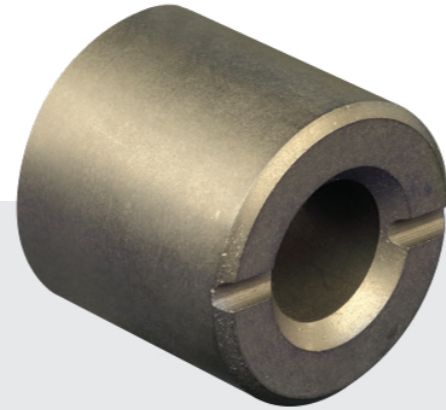
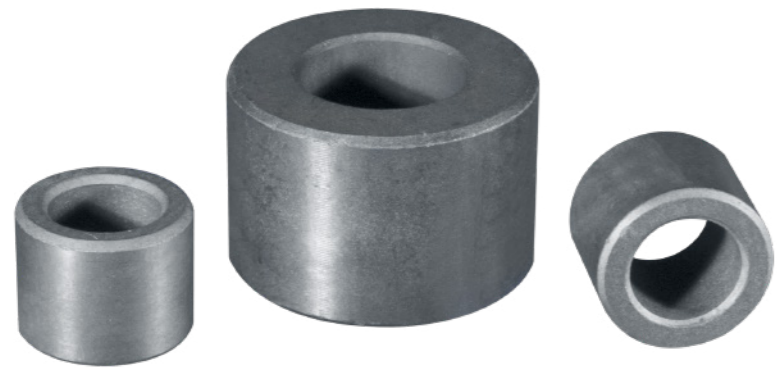

Fuel Pump Bearings

Radial bearings developed from our leading carbon material make the use of ethanol-containing fuel blends possible by providing improved lubrication in high pressure fuel pump environments.



Electronic Leveling Valves

Air suspension, and its contribution to improve driving comfort, is particularly well-established as a valuable feature in heavy vehicles. Morgan produces high purity alumina slider valves to a high flatness tolerance enabling the creation of the air tight seal required for Electronic leveling Modules (EIM). The exceptional hardness offered by ceramic increases reliability throughout the product life cycle .



Electric & Mechanical Water Pump

Worldwide legislation concerning emissions and fuel consumption, is driving improvements in thermal management of vehicles.

Harnessing our world-class design expertise and unique manufacturing capabilities, we work in partnership with some of the world's largest pumps suppliers, developing competitive tailored solutions to meet the increasingly challenging demands of the sector. Morgan offers bearings used in electric and mechanical water pumps for Electrified Vehicles, that can be produced in carbon-graphite and engineered plastic materials.

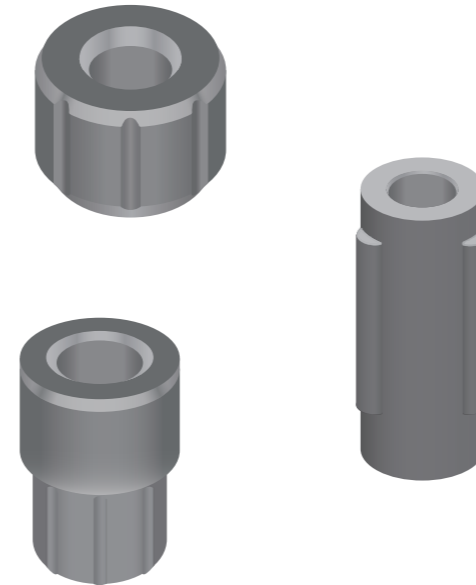
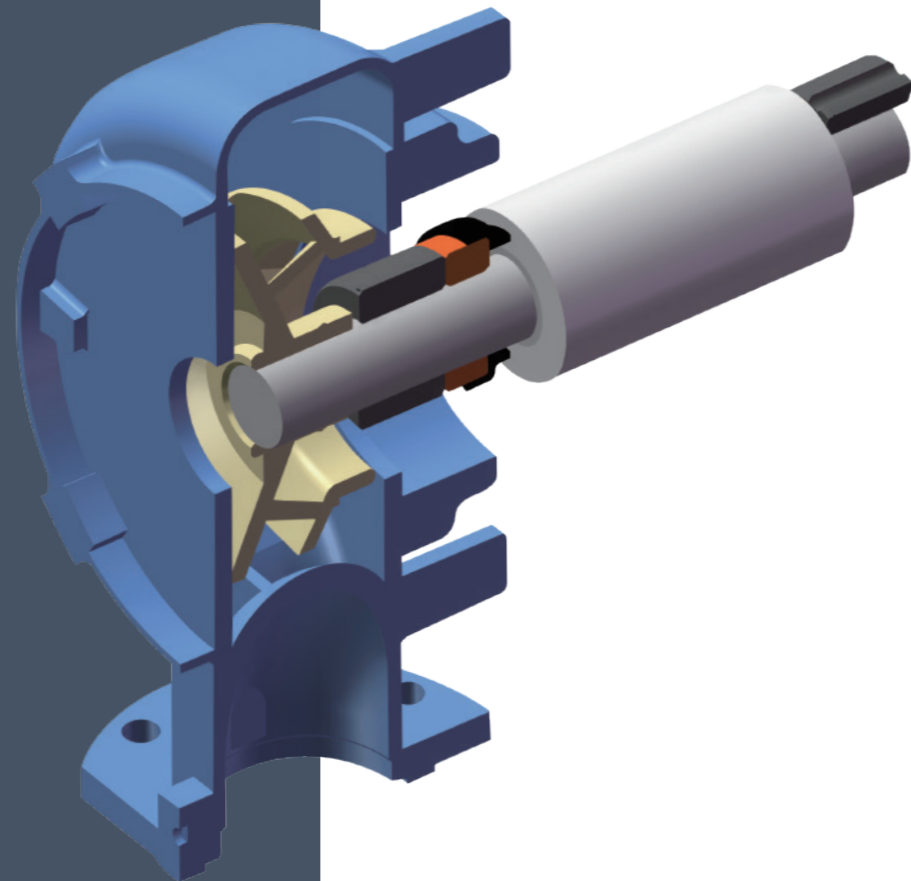

Coolant Pumps used to circulate aggressive coolant means through ICE and HEV/EV are significant enablers of CO₂ reduction targets

Key Advantages of Morgan's Solutions

- Superior wear resistance ensures stable precision fit of components, providing steady noise performance
- Excellent corrosion resistance ensures significant continuous operation of pump at elevated temperatures
- High volume capability at Morgan's global manufacturing sites enabling precision machining capability to achieve excellent finishes for bearings
- Multiple proved grades guaranteeing to satisfy best price-performance ratio linked to customer needs

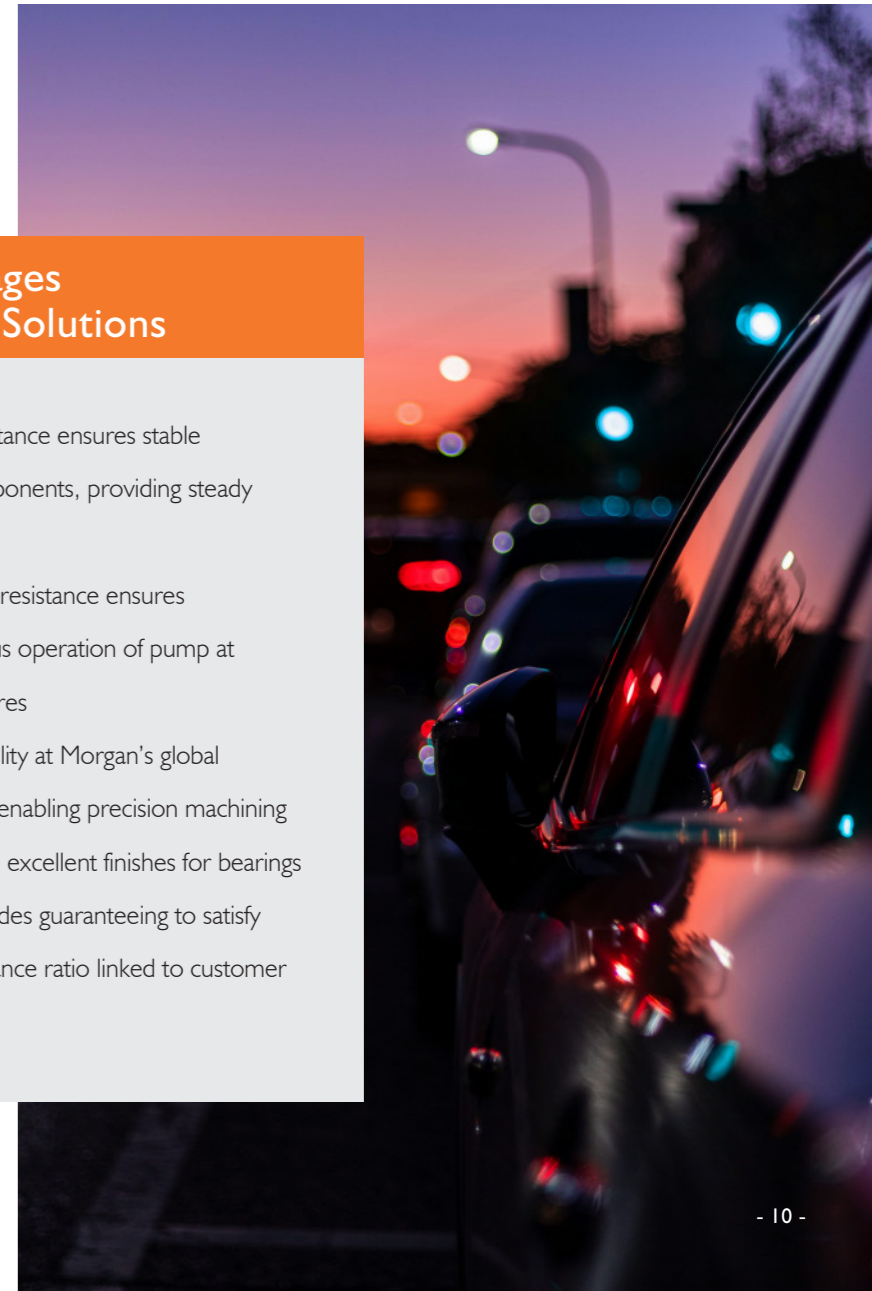

Carbon Brushes for Automobile

Our carbon brushes are industry leading due to their reliable performance, bolstered by 160 years of carbon and graphite materials expertise.

Our global operation network, advanced testing equipment and instruments, paired with our materials knowledge and application experience makes us a trusted industry partner.

We work across multiple industries in applications such as automobiles. As a business we can provide customised solutions to help customers reduce total costs and improve motor performance.

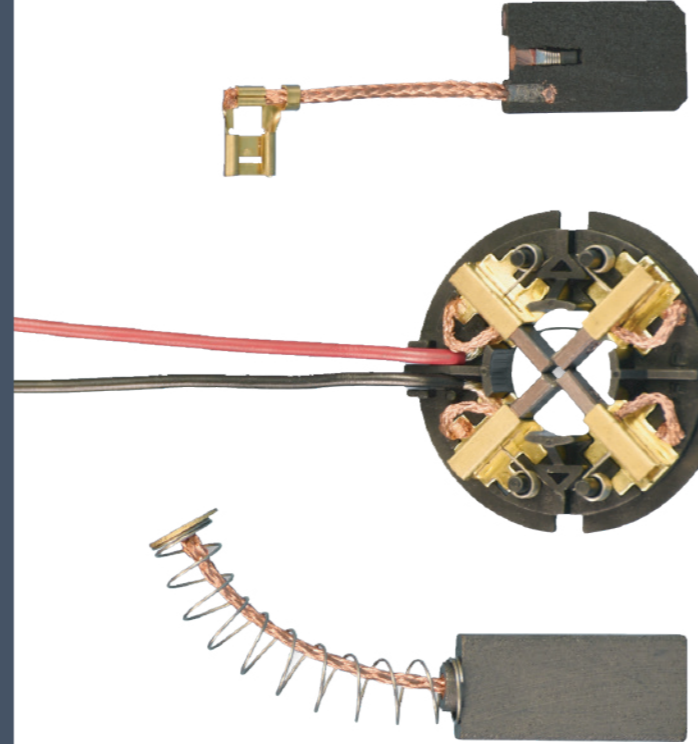

Product Features:

- Reliable material performance
- Unique and exclusive formula
- Excellent product compatibility
- Good commutation performance
- Stable ability to suppress spark
- Noise Vibration Harshness (NVH) properties

Main Advantages:

- Over 160 years of professional experience in manufacture and application of carbon brushes
- Advanced, fully equipped, in-house testing facilities
- Complete manufacturing equipment and operation capability
- Advanced test facility and detecting instruments
- Professional technical team and global application support
- Complete service system and quick response support
- Customised according to customers' specific needs

Benefits to Customers:

- Reliable solutions
- Timely pre-sales and post-sales services
- Professional technical applications support

Diverse Materials

Grade	Description	Contact drop	Friction coefficient	Applications
MH (IM)	Epoxy resin bonded: High contact and outstanding commutating ability	Medium to very high	Very low	120V&230V tools with low current density& home appliance with high speed
MF (H)	Phenolic resin bonded: Low resistivity with capability to withstand a wide range of current density	Medium	Low	Lower than 120V AC&DC motor & home appliance with high current density and BEV motor
CH (EG)	Electro-graphite: High thermal and electrical conductivity; has good strength and filming properties, very resistant to effects of electrical discharges	Low	Low	120V professional tools with high current density Industrial motor or generator ,or traction motor application
MG (CM)	Copper graphite: Low resistivity to cover high current, low voltage applications.	Low	Medium to high	12V&24V DC motors, automotive motors, portable appliances; 120V&230V DC motors with high current density Grounding brush
MP (PM)	Pitch bonded: High contact resistance without using a resin binder, less affected by sparking and overloading	Medium to high	Medium to high	120V&230V professional tools with medium to high current density

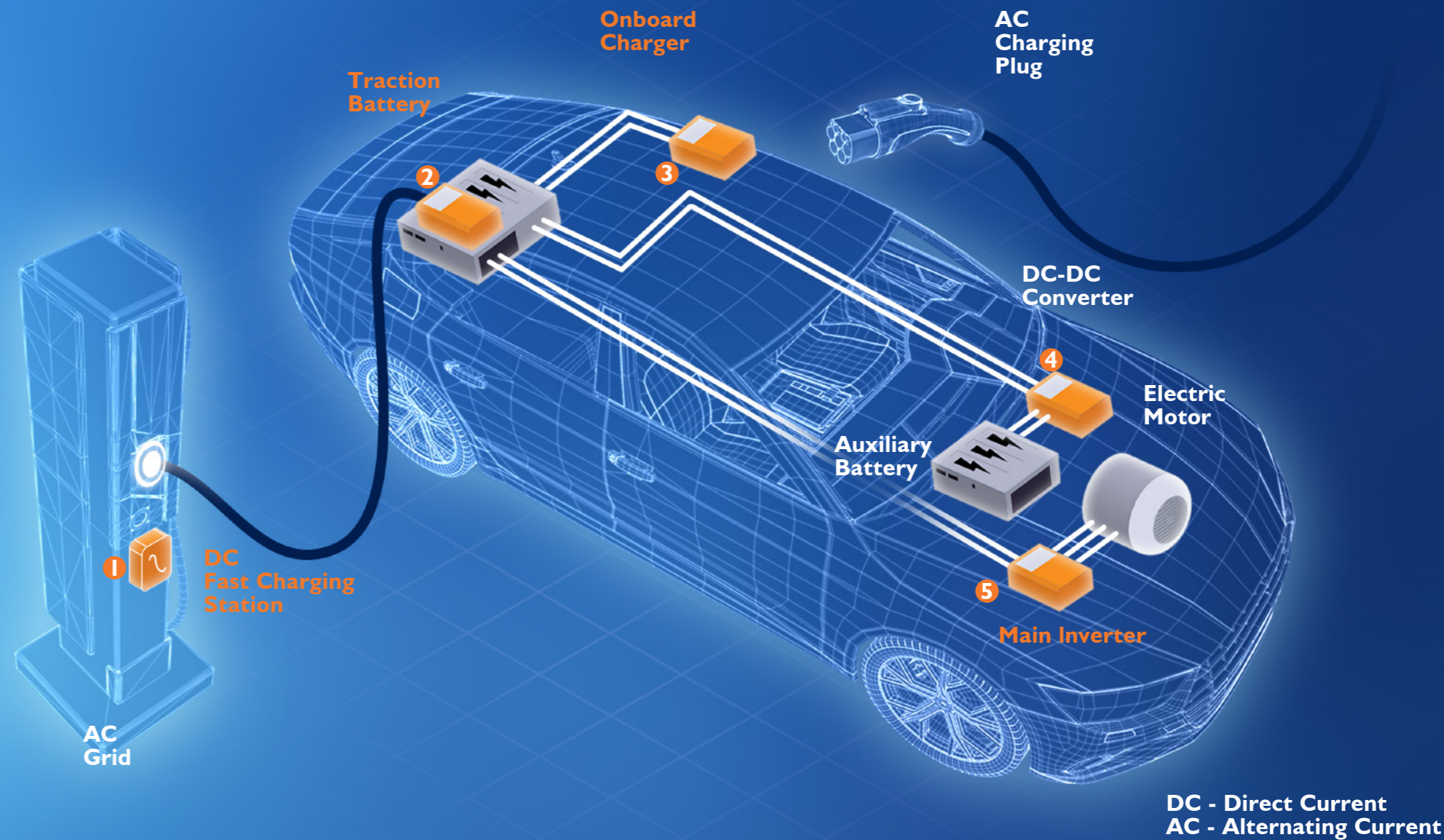

Morgan boasts over 160 years of expertise and application experience in providing specialty graphite and insulation products.

With a rich history of material research and application engineering, we provide customers with comprehensive solutions to meet a variety of challenges.



Carbon and Graphite Soft Felt Insulation Products

Morgan offers a range of high purity soft felts with low thermal conductivity and thermal insulation, used for high-temperature furnaces in vacuum or inert gas environments at up to $>2500^{\circ}\text{C}$.

Rigid Board Insulation Products

Morgan Advanced Materials offers a line of premium Rigid Board Insulation products developed for optimal performance at temperatures up to $>2000^{\circ}\text{C}$ in vacuum or inert atmospheres.

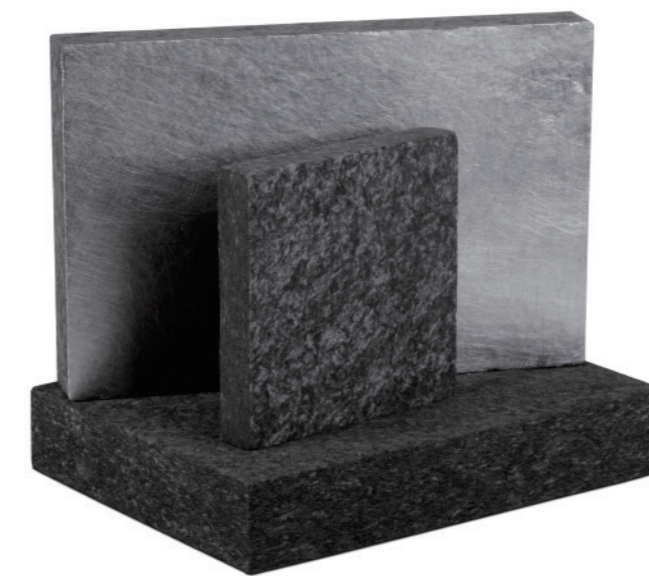



Porous Carbon and Porous Graphite

The porous carbon and porous graphite materials from Morgan are widely used in the furnace for the single crystal SiC growing for enhanced process yield.



Graphite Powder

Morgan offers high purity graphite powder with total metallic impurities less than 10ppm widely used in the single crystal SiC growing, artificial diamond growth and other fields.

